



1 STANDARD EXECUTIONS

- **VCTK**: knob in high resilience polypropylene based (PP) technopolymer.



Stator and rotor in chrome plated zinc-alloy.



Latch cam, screw and washer in zinc-plated steel.



Spring washer in zinc-plated steel.



M22x1.5 nut in zinc-plated steel.



Distance element in aluminium.



- **VCMK-SST**: AISI 304 stainless steel knob, sand-blasted matte finish.



Stator and rotor in AISI 303 stainless steel.



Latch cam in AISI 304L stainless steel.



Spring washer in stainless steel.



M22X1.5 nut in stainless steel.



Distance element in AISI 303 stainless steel.



Screw and washer in stainless steel.

PACKING RING

NBR synthetic rubber.

FEATURES AND APPLICATIONS

Latch cams of VCTK. VCMK. have a pulling-in range of 10mm. Locking is achieved by turning the knob clockwise.

The internal O-ring prevents the ingress of water.

ACCESSORIES ON REQUEST

Sheet metal puncher GN 123 (see page 1557).

ASSEMBLY INSTRUCTIONS

1. Drill a hole in the door as per the drilling template drawing with the axis at a distance of 23 mm from the door frame.

2. Insert frontally the latch body in the hole of the door and screw on the threaded nut.

3. Insert the distance element and the cam by fitting it with the screw.



Drilling template

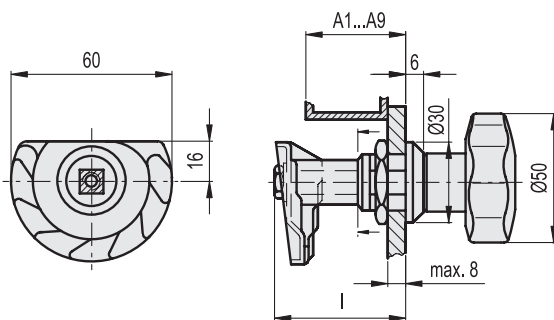
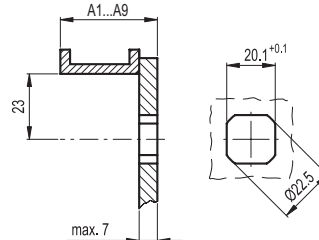

14



15



16



17



18



VCTK.

METRIC

VCMK-SST

INOX STAINLESS STEEL

METRIC

Code	Description	l	A1...A9	△	Code	Description
68701	VCTK.50-A1	28	17+25	119	68801	VCMK.50-SST-A1
68706	VCTK.50-A2	33	22+30	121	68806	VCMK.50-SST-A2
68711	VCTK.50-A3	38	27+35	127	68811	VCMK.50-SST-A3
68716	VCTK.50-A4	43	32+40	128	68816	VCMK.50-SST-A4
68721	VCTK.50-A5	48	37+45	133	68821	VCMK.50-SST-A5
68726	VCTK.50-A6	53	42+50	138	68826	VCMK.50-SST-A6
68731	VCTK.50-A7	58	47+55	141	68831	VCMK.50-SST-A7
68736	VCTK.50-A8	63	52+60	145	68836	VCMK.50-SST-A8
68741	VCTK.50-A9	68	57+65	150	68841	VCMK.50-SST-A9

Latches

1526